

EXAMPLE OF LOW LEVEL VEGETATED BERM FORMATION IN AN URBAN CHANNEL, MANUAL OF RIVER RESTORATION TECHNIQUES

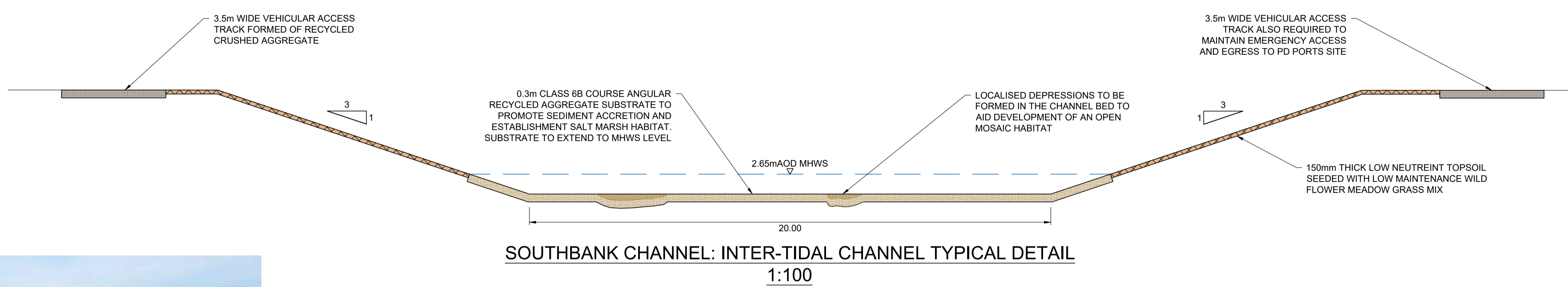

EXAMPLE OF THE LONG TERM ASPIRATIONAL SALT MARSH HABITAT TO ESTABLISH THROUGH TIDAL SEDIMENT ACCRETION AND SELF VEGETATION



<https://consult.environment-agency.gov.uk/solent-and-south-downs/thorney-island-habitat-creation-scheme-information/>

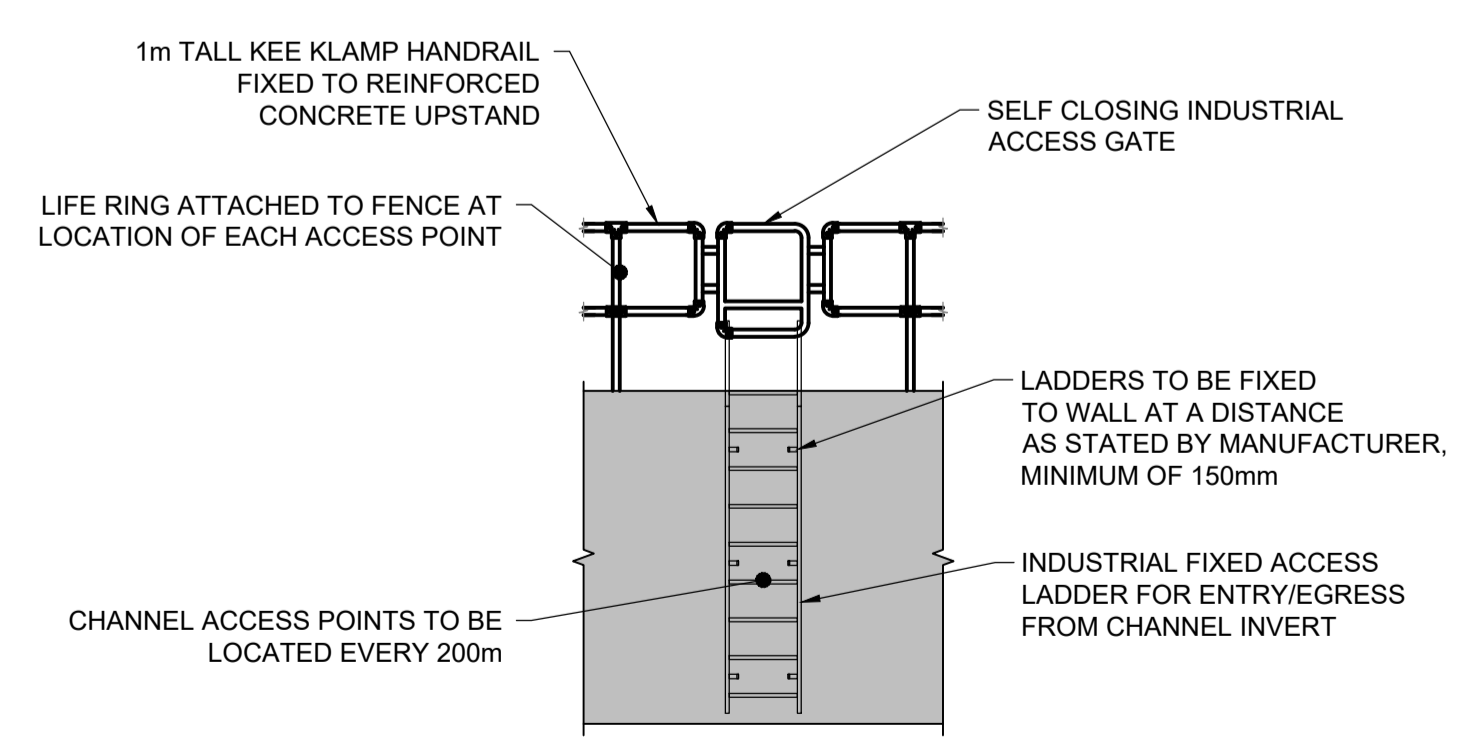

SOUTH BANK CHANNEL: INVERT ACCESS TYPICAL DETAIL 1:50

1	Working near water	Working near water	Working near water
2	Unknown ground conditions		
3	Deep excavations		
4	Contaminated ground		
5	COMAH site	COMAH site	COMAH site
No.	Construction Risk	Maintenance Risk	Demolition Risk

In addition to the hazards/risks normally associated with the types of work detailed on this drawing take note of the above.

**SAFETY, HEALTH AND ENVIRONMENTAL INFORMATION BOX**

**Drawing Notes**

- This drawing is to be read in conjunction with:-
  - TW-SIZ-XX-JBAU-SB-00-DR-C-0001-Home\_Beck\_Key\_Plan
  - TW-SIZ-XX-JBAU-SB-00-DR-C-0002-Home\_Beck\_General\_Arrangement\_High\_Tip\_West
  - TW-SIZ-XX-JBAU-SB-00-DR-C-0003-Home\_Beck\_General\_Arrangement\_High\_Tip\_North
  - TW-SIZ-XX-JBAU-SB-00-DR-C-0004-Home\_Beck\_General\_Arrangement\_Inter\_Tidal\_Channel
  - TW-SIZ-XX-JBAU-SB-00-DR-C-0101-Home\_Beck\_Long\_Section\_Sheet\_1\_of\_4
  - TW-SIZ-XX-JBAU-SB-00-DR-C-0102-Home\_Beck\_Long\_Section\_Sheet\_2\_of\_4
  - TW-SIZ-XX-JBAU-SB-00-DR-C-0103-Home\_Beck\_Long\_Section\_Sheet\_3\_of\_4
  - TW-SIZ-XX-JBAU-SB-00-DR-C-0104-Home\_Beck\_Long\_Section\_Sheet\_4\_of\_4
  - TW-SIZ-XX-JBAU-SB-00-DR-C-0201-Home\_Beck\_Cross\_Sections\_Sheet\_1\_of\_3
  - TW-SIZ-XX-JBAU-SB-00-DR-C-0202-Home\_Beck\_Cross\_Sections\_Sheet\_2\_of\_3
  - TW-SIZ-XX-JBAU-SB-00-DR-C-0203-Home\_Beck\_Cross\_Sections\_Sheet\_3\_of\_3
  - TW-SIZ-XX-JBAU-SB-00-DR-C-0301-South\_Bank\_Details\_Sheet\_1\_of\_4
  - TW-SIZ-XX-JBAU-SB-00-DR-C-0302-South\_Bank\_Details\_Sheet\_2\_of\_4
  - TW-SIZ-XX-JBAU-SB-00-DR-C-0303-South\_Bank\_Details\_Sheet\_3\_of\_4
  - TW-SIZ-XX-JBAU-SB-00-DR-C-0304-South\_Bank\_Details\_Sheet\_4\_of\_4
- All dimensions are in metres unless noted otherwise.
- All levels are in metres relative to ordnance datum Newlyn (mAOD) unless noted otherwise.
- All coordinates are in metres relative to ordnance survey national grid.
- Do not scale from this drawing. All dimensions must be checked/verified on site.
- For clarity purposes existing and proposed services have been omitted from this drawing.

**LEGEND**

- EXCAVATION EXTENT
- INSITU CONCRETE ELEMENT
- REINFORCED CONCRETE ELEMENT
- CLASS 6N STRUCTURAL FILL
- VEGETATED VERGE
- RECYCLED CRUSHED AGGREGATE HARD STANDING
- EROSION RESISTANT 300mm< WELL GRADED WELL ROUNDED SUBSTRATE
- COURSE ANGULAR SUBSTRATE
- GABION BASKET RETAINING WALL

C01	Comments	Issued for Planning Permission								
Rev.:	Date	11/11/21	Drawn	JN	Designed	JA	Checked	ST	Approved	RD
P01	Comments	First issue								
Rev.:	Date	11/10/21	Drawn	MM	Designed	JA	Checked	ST	Approved	RD

Client Approval

A - Approved  
B - Approved with Revisions  
C - Do Not Use

Unit 2.1  
Quantum Court  
Research Avenue South  
Heriot Watt University  
EDINBURGH  
EH14 4AP  
United Kingdom  
T +44 (0)131 3192 940  
E info@jbaconsulting.com  
www.jbaconsulting.com  
Twitter @JBAConsulting



Project **South Bank Arterial Drainage**

Title **South Bank Channel Details Details 4 of 4**  
for

Client **TEESWORKS**

The property of this drawing and design vested in Jeremy Benn Associates Ltd. It shall not be reproduced in whole or in part, nor disclosed to a third party, without the prior written consent of Jeremy Benn Associates Ltd.

Drawn:	M. Morrison	30/09/2021	Designed:	J. Alcock	30/09/2021
Checked:	S. Thomson	11/10/2021	Approved:	R. Dobson	11/10/2021
Project Reference:	2021s1087		Scale:	As Shown @ A1	
Drawing Number:	TW-SIZ-XX-JBAU-SB-00-DR-C-0304	Status:	A1	Revision:	C01
		Sheet Size:	A1		